

OPTI PROD 2022

PRIX PROMOTIONNELS NET HT
OFFRE VALABLE JUSQU'AU 31-12-2022*

SOUS RÉSERVE
DE VARIATIONS
TARIFAIRES



**TeCHMO**
SaTeCH
GROUPE
Partenaire d'usage



HSS 5% COBALT
< 2,5D



HSS 5% COBALT
< 2,5D



FRITTÉ
< 3D



FRITTÉ
< 3D

TOLÉRANCE ENTRÉE GOUJURE	A15S TIN		A70S TIN		P15 TIN		P70 TIN	
	6H B=4 5 FILETS DROITE		6H C=2 3 FILETS HÉLICOÏDALE 40°		6HX B=4 5 FILETS DROITE		6HX C=2 3 FILETS HÉLICOÏDALE 45°	
	CODE	Prix promo € HT	CODE	Prix promo € HT	CODE	Prix promo € HT	CODE	Prix promo € HT
M2 x 0,40					042510	23,70		
M2,5 x 0,45					042511	23,70		
M3 x 0,50	041452	12,49	047504	12,49	042512	21,11	042528	23,32
M4 x 0,70	041453	12,50	047505	12,50	042513	21,11	042529	23,32
M5 x 0,80	041454	12,50	047506	12,50	042514	21,11	042530	23,32
M6 x 1,00	041455	12,50	047507	12,50	042515	21,54	042531	23,32
M8 x 1,25	041456	13,76	047508	13,76	042516	26,94	042532	29,73
M10 x 1,50	041457	17,02	047509	17,02	042517	33,58	042533	36,32
M12 x 1,75	041458	21,36	047510	21,36	042518	42,45	042534	46,51
M14 x 2,00	041459	36,03	047511	36,03	042519	56,59	042535	62,73
M16 x 2,00	041460	36,03	047512	36,03	042520	63,81	042536	72,11
M18 x 2,50					042521	88,02	042537	92,00
M20 x 2,50	041462	51,05	047515	51,05	042522	115,90	042538	119,57



HSS 5% COBALT



HSS 5% COBALT



HSS 5% COBALT

	A20S TiCN		A34 TIN		A61	
	CODE	Prix promo € HT	CODE	Prix promo € HT	CODE	Prix promo € HT
2 64 UNF	040919	28,28	040831	24,99	047429	23,12
3 56 UNF	040920	27,13	040832	23,99	047430	21,72
4 48 UNF	040921	26,41	040833	23,19	047431	20,84
5 44 UNF	040922	26,41	040834	23,19	047432	20,84
6 40 UNF	040923	25,39	040835	22,66	047433	19,86
8 36 UNF	040924	25,39	040836	22,66	047434	19,86
10 32 UNF	040925	26,41	040837	23,38	047435	20,84
12 28 UNF	040926	28,54	040838	25,20	047436	23,38
1/4 UNF	040927	28,54	040839	25,20	047437	23,38
5/16 UNF	040928	32,29	040840	28,73	047438	24,13
3/8 UNF	040929	34,88	040841	31,41	047439	24,66
7/16 UNF	040930	44,31	040842	39,69	047440	32,88
1/2 UNF	040931	45,83	040843	41,02	047441	33,88
9/16 UNF	040932	66,29	040844	58,87	047442	51,31
5/8 UNF	040933	65,43	040845	58,61	047443	48,65
3/4 UNF	040934	102,36	040846	93,15	047444	65,29
7/8 UNF	040935	128,10	040847	115,99	047445	84,14
1" 12 UNF	040936	197,59	040848	179,88	047447	124,02

TARAUDS MACHINE VERGNANO | HSS 5% COLBALT - UNC



			A19S TiCN		A60S TiCN		A33 TiN	
			CODE	Prix promo € HT	CODE	Prix promo € HT	CODE	Prix promo € HT
2	56	UNC	040867	27,13	040849	27,39	040885	23,99
3	48	UNC	040868	26,13	040850	26,53	040886	23,19
4	40	UNC	040869	24,66	040851	24,85	040887	21,86
5	40	UNC	040870	24,66	040852	24,85	040888	21,86
6	32	UNC	040871	23,73	040853	24,06	040889	21,25
8	32	UNC	040872	23,73	040854	24,06	040890	21,25
10	24	UNC	040873	25,66	040855	25,87	040891	22,72
12	24	UNC	040874	26,00	040856	26,41	040892	23,06
1/4	20	UNC	040875	26,81	040857	28,54	040893	23,73
5/16	18	UNC	040876	30,47	040858	30,82	040894	27,34
3/8	16	UNC	040877	33,27	040859	33,67	040895	30,07
7/16	14	UNC	040878	41,56	040860	41,96	040896	37,29
1/2	13	UNC	040879	42,89	040861	43,43	040897	38,48
9/16	12	UNC	040880	62,28	040862	62,75	040898	55,60
5/8	11	UNC	040881	62,09	040863	62,67	040899	55,60
3/4	10	UNC	040882	96,48	040864	97,37	040900	88,20
7/8	9	UNC	040883	122,08	040865	123,29	040901	111,05
1"	8	UNC	040884	185,83	040866	185,83	040902	168,72

TARAUDS MACHINE VERGNANO | HSS FRITTÉ - G



			P18 TiH1		P59 TiH1	
			CODE	Prix promo € HT	CODE	Prix promo € HT
1/8	28F		040807	42,49	040800	42,89
1/4	19F		040808	62,00	040801	62,54
3/8	19F		040809	76,04	040802	76,70
1/2	14F		040810	128,50	040803	130,16
5/8	14F		040811	153,14	040804	154,89
3/4	14F		040812	220,71	040805	222,44
1"11	11F		040813	317,12	040806	319,74

TARAUDS À REFOULER VERGNANO | HSSK FRITTÉ - M



INOX | ACIER



TOLÉRANCE ENTRÉE	P80 TIN		P80N TIN		P80 V MAXX	
	6HX		6HX		6HX	
	C=2	3 FILETS	C=2	3 FILETS	C=2	3 FILETS
	CODE	Prix promo € HT	CODE	Prix promo € HT	CODE	Prix promo € HT
M2 x 0,40	042592	31,75	042608	33,40	047841	35,43
M2,5 x 0,45	042593	29,40	042609	31,55	047842	33,46
M3 x 0,50	042594	26,30	042610	28,71	047843	29,98
M3,5 x 0,60	042595	26,30	042611	28,13	047844	29,98
M4 x 0,70	042596	26,81	042612	28,13	047845	29,98
M5 x 0,80	042597	26,30	042613	28,71	047846	29,98
M6 x 1,00	042598	26,30	042614	28,13	047847	29,98
M8 x 1,25	042599	33,15	042615	36,12	047848	37,76
M10 x 1,50	042600	41,95	042616	44,68	047849	47,72
M12 x 1,75	042601	49,62	042617	54,11	047850	56,46
M14 x 2,00	042602	66,66	042618	71,22	047851	76,03
M16 x 2,00	042603	82,95	042619	88,83	047852	94,41
M18 x 2,50			042620	138,96		
M20 x 2,50			042621	206,56		

TARAUDS MACHINE BASS | INOX | ACIER | TITANE



INOX | ACIER | ALUMINIUM

DOMINANT 1 VA45



TARAUDS INOX ACIER ALU.	CODE	Prix promo € net HT
TAR BASS TH 16.6141 REV HL M3	043020	26,17
TAR BASS TH 16.6141 REV HL M4	043021	26,17
TAR BASS TH 16.6141 REV HL M5	043022	27,45
TAR BASS TH 16.6141 REV HL M6	043023	27,80
TAR BASS TH 16.6141 REV HL M8	043024	34,54
TAR BASS TH 16.6141 REV HL M10	043025	39,25
TAR BASS TH 16.6241 REV HL M12	043026	52,71
TAR BASS TH 16.6241 REV HL M14	043027	67,98
TAR BASS TH 16.6241 REV HL M16	043028	75,60
TAR BASS TH 16.6241 REV HL M20	043029	111,22

- HSSE PM
- ENTRÉE : C (2-3)
- REVÊTEMENT : TIALN
- GOUJURE : HÉLICOÏDALE 45°

BASS
TECHNIK FÜR GEWINDE

INOX | ACIER | ALUMINIUM

VARIANT 1 VA



TARAUDS INOX ACIER ALU.	CODE	Prix promo € net HT
TAR BASS GUN 14.2311 REV HL M3	043035	23,44
TAR BASS GUN 14.2311 REV HL M4	043036	24,36
TAR BASS GUN 14.2311 REV HL M5	043037	25,99
TAR BASS GUN 14.2311 REV HL M6	043038	26,35
TAR BASS GUN 14.2311 REV HL M8	043039	32,53
TAR BASS GUN 14.2311 REVHL M10	043040	36,17
TAR BASS GUN 14.2411 REVHL M12	043041	49,80
TAR BASS GUN 14.2411 REVHL M16	043042	63,61
TAR BASS GUN 14.2411 REVHL M20	043043	98,13

- HSSE PM
- ENTRÉE : B (3,5 - 5)
- REVÊTEMENT : TIALN
- GOUJURE : DROITE

BASS
TECHNIK FÜR GEWINDE

TITANE | INOX

AVANT 1 TIH13



TARAUDS TITANE ACIER	CODE	Prix promo € net HT
TAR BASS TH 25.2131 M3 TICN	043050	27,62
TAR BASS TH 25.2131 M4 TICN	043051	28,35
TAR BASS TH 25.2131 M5 TICN	043052	30,35
TAR BASS TH 25.2131 M6 TICN	043053	30,53
TAR BASS TH 25.2131 M8 TICN	043054	37,07
TAR BASS TH 25.2131 M10 TICN	043055	42,89
TAR BASS TH 25.2231 M12 TICN	043056	58,88

- HSSE PM
- ENTRÉE : C (2 - 3)
- REVÊTEMENT : TICN
- GOUJURE : HÉLICOÏDALE 13°

BASS
TECHNIK FÜR GEWINDE

TITANE | INOX

VARIANT 1 TIH



TARAUDS TITANE ACIER	CODE	Prix promo € net HT
TAR BASS GUN 25.2311 M3 TICN	043060	27,07
TAR BASS GUN 25.2311 M4 TICN	043061	27,80
TAR BASS GUN 25.2311 M5 TICN	043062	30,53
TAR BASS GUN 25.2311 M6 TICN	043063	31,63
TAR BASS GUN 25.2311 M8 TICN	043064	37,07
TAR BASS GUN 25.2311 M10 TICN	043065	43,99
TAR BASS GUN 25.2411 M12 TICN	043066	57,80

- HSSE PM
- ENTRÉE : B (3,5 - 5)
- REVÊTEMENT : TICN
- GOUJURE : DROITE

VARIANT TIH TICN



TYPE	EXÉCUTION	PAS	DIAM	PAS	CODE	Prix promo € net HT
VARIANT 1 TIH	TICN	MJ	4	0,70	043069	57,03
VARIANT 1 TIH	TICN	MJ	5	0,80	043070	63,14
VARIANT 1 TIH	TICN	MJ	6	1,00	043071	64,77
VARIANT 1 TIH	TICN	MJ	8	1,25	043087	76,99
VARIANT 1 TIH	TICN	MJ	10	1,50	043088	91,24
VARIANT 1 TIH	TICN	UNJC	No6	32	043089	46,44
VARIANT 1 TIH	TICN	UNJC	No8	32	043072	46,85
VARIANT 1 TIH	TICN	UNJC	No10	24	043073	50,93
VARIANT 1 TIH	TICN	UNJC	1/4"	20	043074	52,95
VARIANT 1 TIH	TICN	UNJC	5/16"	18	043090	62,33
VARIANT 1 TIH	TICN	UNJC	3/8"	16	043091	73,32
VARIANT 1 TIH	TICN	UNJF	No6	40	043092	49,30
VARIANT 1 TIH	TICN	UNJF	No8	36	043075	49,69
VARIANT 1 TIH	TICN	UNJF	No10	32	043076	54,18
VARIANT 1 TIH	TICN	UNJF	1/4"	28	043077	56,63
VARIANT 1 TIH	TICN	UNJF	5/16"	24	043093	66,80
VARIANT 1 TIH	TICN	UNJF	3/8"	24	043094	78,21

VARIANT TIH13 TICN



TYPE	EXÉCUTION	PAS	DIAM	PAS	CODE	Prix promo € net HT
AVANT 1 TIH13	TICN	MJ	4	0,70	043095	54,18
AVANT 1 TIH13	TICN	MJ	5	0,80	043078	59,47
AVANT 1 TIH13	TICN	MJ	6	1,00	043079	61,91
AVANT 1 TIH13	TICN	MJ	8	1,25	043080	74,13
AVANT 1 TIH13	TICN	MJ	10	1,50	043096	85,54
AVANT 1 TIH13	TICN	UNJC	No6	32	043097	43,99
AVANT 1 TIH13	TICN	UNJC	No8	32	043098	44,41
AVANT 1 TIH13	TICN	UNJC	No10	24	043081	48,48
AVANT 1 TIH13	TICN	UNJC	1/4"	20	043082	49,69
AVANT 1 TIH13	TICN	UNJC	5/16"	18	043083	59,47
AVANT 1 TIH13	TICN	UNJC	3/8"	16	043099	69,66
AVANT 1 TIH13	TICN	UNJF	No6	40	043100	46,85
AVANT 1 TIH13	TICN	UNJF	No8	36	043101	47,67
AVANT 1 TIH13	TICN	UNJF	No10	32	043084	49,69
AVANT 1 TIH13	TICN	UNJF	1/4"	28	043085	53,37
AVANT 1 TIH13	TICN	UNJF	5/16"	24	043086	63,14
AVANT 1 TIH13	TICN	UNJF	3/8"	24	043102	73,74

VARIANT H VAP



TARAUDS INOX ACIER	CODE	Prix promo € net HT
TAR BASS LP 882103 GUN VAP M3	043010	13,08
TAR BASS LP 882104 GUN VAP M4	043011	13,46
TAR BASS LP 882105 GUN VAP M5	043012	14,43
TAR BASS LP 882106 GUN VAP M6	043013	14,43
TAR BASS LP 882108 GUN VAP M8	043014	16,74
TAR BASS LP 882110 GUN VAP M10	043015	20,00
TAR BASS LP 882112 GUN VAP M12	043016	23,28
TAR BASS LP 882114 GUN VAP M14	043019	30,38
TAR BASS LP 882116 GUN VAP M16	043017	33,46
TAR BASS LP 882120 GUN VAP M20	043018	50,77

- HSSE PM
- ENTRÉE : B (3,5 - 5,4)
- REVÊTEMENT : VAP
- TROU BORGNE DÉBOUCHANT

DOMINANT HZ38 VAP



TARAUDS INOX ACIER	CODE	Prix promo € net HT
TAR BASS LP 884503 TH VAP M3	043001	13,46
TAR BASS LP 884504 TH VAP M4	043002	14,05
TAR BASS LP 884505 TH VAP M5	043003	15,00
TAR BASS LP 884506 TH VAP M6	043004	15,00
TAR BASS LP 884508 TH VAP M8	043005	17,31
TAR BASS LP 884510 TH VAP M10	043006	20,77
TAR BASS LP 884512 TH VAP M12	043007	24,05
TAR BASS LP 884514 TH VAP M14	043031	28,66
TAR BASS LP 884516 TH VAP M16	043008	34,62
TAR BASS LP 884520 TH VAP M20	043009	46,15

- HSSE PM
- ENTRÉE : C (2 - 3)
- REVÊTEMENT : VAP
- TROU BORGNE DÉBOUCHANT



INOX | ACIER | ALUMINIUM | FONTE



HSSE

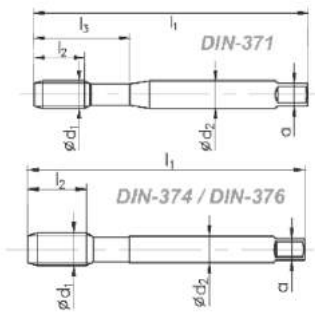

800X

C-R40-TN2

B-TN2



< 2,5 D



< 3 D

**TYPE DE MATÉRIEL
REVÊTEMENT
ENTRÉE
GOJURE**

M	P	L1	L2	L3	D2	a		INDEX	
D1			R40						
M3	0,50	56	10	5	18	3,5	2,7	2,50	0030
M4	0,70	63	12	7	21	4,5	3,4	3,30	0040
M5	0,80	70	14	8	25	6,00	4,90	4,20	0050
M6	1,00	80	18	10	35	6,00	4,90	5,00	0060
M8	1,25	90	20	13	35	8,00	6,20	6,80	0080
M10	1,50	100	20	15	39	10,00	8,00	8,50	0100
M8x1	1,00	90	20	10		6,00	4,90	7,00	0083
M10x1	1,00	90	20	13		7,00	5,50	9,00	0103
M10x1,25	1,25	100	20	15		7,00	5,50	8,80	0104
M12	1,75	110	24	18		9,00	7,00	10,20	0120
M14	2,00	110	25	20		11,00	9,00	12,00	0140
M16	2,00	110	32	20		12,00	9,00	14,00	0160
M18	2,50	125	32	25		14,00	11,00	15,50	0180
M20	2,50	140	32	25		16,00	12,00	17,50	0200
M22	2,50	140	32	25		18,00	14,50	19,50	0220
M24	3,00	160	38	30		18,00	4,50	21,00	0240
M27	3,00	160	38	30		20,00	16,00	24,00	0270
M30	3,50	180	40	35		22,00	18,00	26,00	0300
M33	3,50	180	45	35		25,00	22,00	29,50	0330
M36	4,00	200	50	40		28,00	22,00	32,00	0360
M12x1,5	1,50	100	20	5		9,00	7,00	10,20	0125
M14x1,5	1,50	100	20	7		11,00	9,00	12,00	0145
M16x1,5	1,50	100	20	8		12,00	9,00	14,00	0162

**HSSE
TIALN + TiN
C / 2 3F
HÉLICOÏDALE 45°**

**HSSE
TIALN + TiN
B / 4 5F
DROITE**

C2 513X01	C2 113X01
CODE	CODE
PRIX PROMO	PRIX PROMO
DIN 371	
045751	045362
8,98	8,60
045753	045364
9,06	8,66
045756	045367
9,88	9,48
045758	045369
10,23	9,82
045761	045372
12,28	11,75
045765	045376
16,12	15,48
DIN 376	
045492	045486
15,83	15,12
045493	045487
19,46	18,62
045494	045488
17,02	15,91
DIN 374	
045778	045389
23,08	21,45
045782	045393
30,51	28,31
045787	045399
33,06	30,66
045790	045402
44,92	41,63
045794	045406
49,08	45,58
045798	045410
66,34	61,42
045802	045414
67,45	62,86
045808	045420
86,17	84,06
045813	045425
101,25	98,77
045818	045430
145,28	141,46
045823	045435
195,60	190,34
DIN 374	
045495	045489
26,69	24,75
045496	045490
35,48	32,82
045497	045491
37,06	34,32

TARAUDS MACHINE FANAR | MASTER TAP - M



TITANE | INOX | ACIER | ALUMINIUM | FONTE - TARAUDS FRITTÉ



HSSE
PM

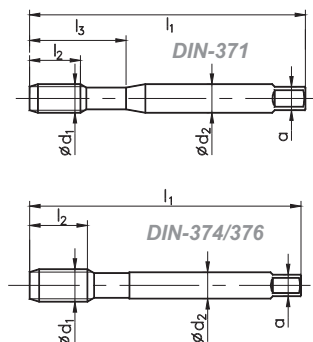

MASTER TAP

B

C-R45



< 3 D

< 2,5 D

ISO2 (H6)
TIALN

B = 4 5 FILETS
DROITE

ISO2 (H6)
TIALN

C = 2 3 FILETS
HÉLICOÏDALE 45°

TOLÉRANCE
REVÊTEMENT
ENTRÉE
GOUJURE

M D1	P	L1	L2	L3	D1	D2	D3	C4 118M01		C4 528M01	
								CODE	PRIX PROMO	CODE	PRIX PROMO
2	0,4	45	8	12	2,8	2,1	1,6	045711	18,34	045719	20,38
2,5	0,45	50	5	14	2,8	2,1	2,05	045712	18,34	045720	20,38
3	0,50	56	5	18	3,5	2,1	2,50	045713	14,19	045721	15,78
4	0,70	63	7	21	4,5	3,4	3,30	045714	14,93	045722	16,60
5	0,80	70	8	25	6	4,9	4,20	045715	16,24	045723	18,05
6	1,00	80	10	30	6	4,9	5,00	045716	16,79	045724	18,69
8	1,25	90	13	35	8	6,2	6,80	045717	20,21	045725	22,45
10	1,50	100	15	39	10	8	8,50	045718	26,53	045726	29,48
								D4 118M31		D4 528M01	
								DIN 376		DIN 376	
12	1,75	110	18		9	7	10,20	045727	39,12	045730	43,50
14	2,00	110	20		11	9	12,00	045728	51,31	045731	57,00
16	2,00	110	20		12	9	14,00	045729	55,16	045732	61,29

TARAUDS MACHINE FANAR | MASTER TAP - UNC



INOX | ACIER | ALUMINIUM | FONTE - TARAUDS FRITTÉ



HSSE
PM

HL

DIN
371

DIN
376

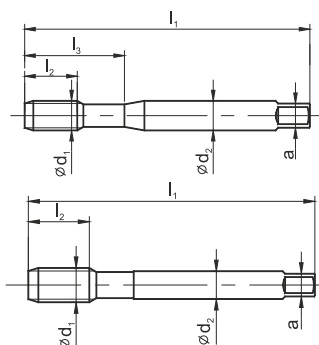

TYPE DE TROU
QUALITÉ
REVÊTEMENT
ENTRÉE
GOUJURE

MASTERTAP

B-HL

C-R45-HL



< 3 D



HSSE PM
TIALN
B / 4 5P
DROITE



< 2,5 D



HSSE PM
TIALN
C / 2 3P
HÉLICOÏDALE 45°

UNC	D1	1"/P	P	L1	L2	L3	D2	a		INDEX	C4 118M01 CODE PRIX PROMO DIN 371		C4 528M01 CODE PRIX PROMO DIN 371		
No 2	56	2,184	56	0,455	45	10	13	2,8	2,1	1,85	4102	044055	11,37	044067	26,83
No 4	40	2,844	40	0,635	56	5	18	3,5	2,7	2,35	4104	045983	18,49	044068	21,09
No 5	40	3,175	40	0,635	56	7	8	3,5	2,7	2,65	4105	044056	17,80	044069	20,57
No 6	32	3,505	32	0,794	56	6	20	4,0	3,0	2,85	4106	045989	17,80	044070	20,57
No 8	32	4,165	32	0,794	63	7	21	4,5	3,4	3,50	4108	044057	16,02	044071	19,35
No 10	24	4,826	24	1,058	70	8	25	6,0	4,9	3,90	4110	044058	17,77	044072	19,28
No 12	24	5,486	24	1,058	80	10	30	6,0	4,9	4,50	4112	044059	18,62	044073	20,22
1/4	20	6,350	20	1,270	80	13	30	7,0	5,5	5,10	4127	044060	19,40	044074	25,22
5/16	18	7,938	18	1,411	90	13	35	8,0	6,0	6,60	4128	044061	21,69	044075	25,22
3/8	16	9,525	16	1,588	100	15	39	10,0	8,0	8,00	4129	044062	28,85	044076	31,62
												D4 118M31 DIN 376		D4 528M01 DIN 376	
7/16	14	11,112	14	1,814	100	15		8,0	6,2	9,40	4130	044063	35,60	044077	38,51
1/2	13	12,700	13	1,954	110	18		9,0	7,0	10,80	4131	044064	50,03	044078	53,65
9/16	12	14,288	12	2,117	110	20		11,0	9,0	12,20	4132	044065	49,45	044079	53,54
5/8	11	15,875	11	2,309	110	22		12,0	9,0	13,50	4133	044066	45,74	044080	49,40



INOX | ACIER | ALUMINIUM | FONTE - TARAUDS FRITTÉ



HSSE
PM

HL

DIN
371

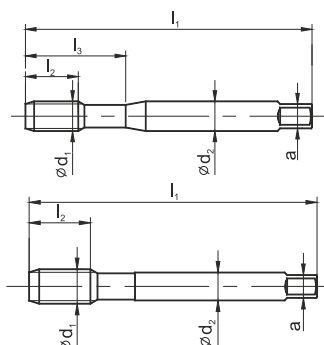

TYPE DE TROU
QUALITÉ
REVÊTEMENT
ENTRÉE
GOUJURE

UNF	D1	1"/P	P	L1	L2	L3	D2	a		INDEX	
No 4	48	2,844	48	0,529	56	5	18	3,50	2,7	2,40	4204
No 5	44	3,175	44	0,557	56	7	18	3,50	2,7	2,70	4205
No 6	40	3,505	40	0,635	56	6	20	4,00	3,0	2,95	4206
No 8	36	4,185	36	0,705	63	7	21	4,50	3,4	3,50	4208
No 10	32	4,826	32	0,794	70	8	25	6,00	4,9	4,10	4210
No 12	28	5,486	28	0,907	80	10	30	6,00	4,9	4,60	4212
1/4	28	6,350	28	0,907	80	10	30	7,00	5,5	5,50	4227
5/16	24	7,938	24	1,058	90	13	35	8,00	6,0	6,90	4228
3/8	24	9,525	24	1,058	100	15	39	10,00	8,0	8,50	4229

MASTERTAP

B-HL

C-R45-HL



< 3 D



HSSE PM
TIALN
B / 4 5P
DROITE



< 2,5 D



HSSE PM
TIALN
C / 2 3P
HÉLICOÏDALE 45°

C4 118M01		C4 528M01	
CODE	PRIX PROMO	CODE	PRIX PROMO
DIN 371		DIN 371	
044081	20,89	044094	23,83
044082	20,12	044095	23,28
044083	20,12	044096	23,28
044084	18,08	044097	21,88
044085	23,86	044098	25,95
044086	21,03	044099	22,83
044087	21,72	044100	29,00
044088	24,32	044101	29,00
044089	32,31	044102	36,37

D4 118M01		D4 528M01	
CODE	PRIX PROMO	CODE	PRIX PROMO
DIN 376		DIN 376	
044090	39,86	044103	43,14
044091	56,25	044104	61,34
044092	56,83	044105	61,58
044093	52,12	044106	56,29

TARAUDS MACHINE FANAR | MASTER TAP - G



INOX | ACIER | ALUMINIUM | FONTE - TARAUDS FRITTÉ



HSSE
PM

HL

DIN
5156

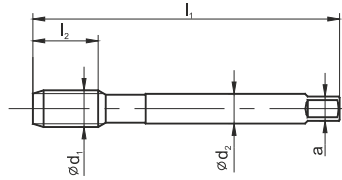

TYPE DE TROU
QUALITÉ
REVÊTEMENT
ENTRÉE
GOUJURE

MASTERTAP

B-HL

C-R45-HL



< 3 D



< 2,5 D



HSSE PM
TIALN
B / 4 5P
DROITE

HSSE PM
TIALN
C / 2 3P
HÉLICOÏDALE 45°

G	D1	1"/P	P	L1	L2	L3	D2	a	INDEX	D4 118M01		D4 528M01	
										CODE	PRIX PROMO	CODE	PRIX PROMO
G1/8	9,728	28	0,907	90	10		7	5,5	8,80	3123	DIN 371	044115	36,98
G1/4	13,157	19	1,337	100	14		11	9,0	11,80	3127	34,24	044116	61,21
G3/8	16,662	19	1,337	100	15		12	9,0	15,25	3129	56,41	044117	67,17
G1/2	20,955	14	1,814	125	17		16	12,0	19,00	3131	62,60	044118	83,02
G5/8	22,911	14	1,814	125	20		18	14,5	21,00	3133	77,10	044119	126,07
G3/4	26,441	14	1,814	140	20		20	16,0	24,50	3135	116,67	044120	141,41
G7/8	30,201	14	1,814	150	22		22	18,0	28,25	3137	131,05	044121	185,33
G1	33,249	11	2,309	160	24		25	20,0	30,75	3139	171,72	044122	256,05

LUBRIFIANTS POUR TARAUDAGE

LUBRIFIANT	Articles	Code	Prix tarif € HT
RTD SPRAY LUBRIFIANT AEROSOL 400 ML	R53011	049002	29,09
RTD PÂTE LUBRIFIANTE POT 500G	R53023	049003	20,27
RTD LUBRIFIANT LIQUIDE BURETTE 400G	R53072	049004	29,09
RTD 5 LITRES LIQUIDE	R53076	049006	273,80



TARAUDS À REFOULER FANAR | INOX | ACIER



INOX | ACIER | ALUMINIUM

AVEC GOUJURE LUBRIFICATION

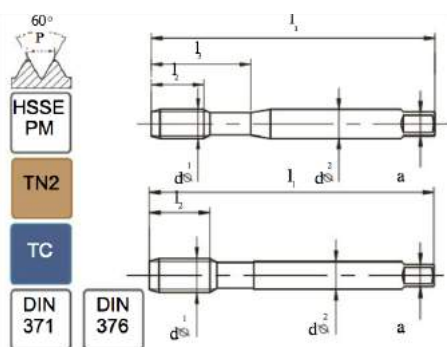

C-SR-TN2



C-SR-TC
METRIC



QUALITÉ DU MATÉRIEL
REVÊTEMENT
ENTRÉE

M D1	P	L1	L2	L3	D2	a		INDEX	HSSE PM TIALN + TiN C/2 3 P		HSSE PM TIALN + TiN C/2 3 P	
									C4 923005 CODE DIN 371	PRIX PROMO	C4 925005 CODE DIN 371	PRIX PROMO
3	0,50	59	18	18	3,5	2,7	2,80	0030	045735	14,47	045973	14,69
4	0,70	63	21	21	4,5	3,4	3,70	0040	045736	14,47	045974	14,69
5	0,80	70	25	25	6	4,9	4,65	0050	045737	15,95	045975	16,12
6	1,00	80	30	30	6	4,9	5,60	0060	045738	16,78	045976	16,95
8	1,00	90	35	35	8	6,2	7,45	0080	045739	20,43	045977	20,72
10	1,50	100	35	35	10	8	9,35	0100	045740	24,97	045978	25,36

BRAS DE TARAUDAGE PNEUMATIQUE

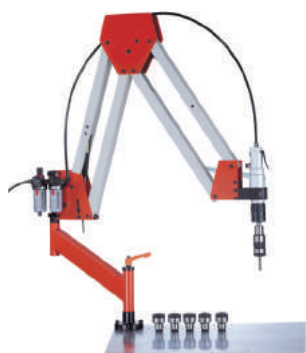

MODÈLE	MPD 12/II	MPD 16/II	MPD 22/II
P0	130000 10312	P0 130000 10316	P0 130000 10322
CAP	M3 M12	M3 M16	M3 M22
N (TR/MIN)	400	300	120/300
SURFACE DE TRAVAIL	RMAX = 1900 MM		RMIN = 200 MM
POIDS (KG)	23	27	39
COUPLE <MAX. (NM)	32	12	100
DÉBIT AIR	840	840	935
ADAPTATEURS LIVRÉS	FZS19/M4,5,6,8,10,12	FZS19/M6,8,10,12,14,16	FZS19/M6,8,10,12,16,20
ADAPTATEURS EN OPTION	FZS19/M3	FZS19/M3,4,5 + FR31/19	FZS19/M3,4,5 + FR31/19 + FZS31/M14,18,22
CODE	045745	045746	045747
PRIX PROMO € NET HT	2 805,95 1 930,67	4 212,59 2 979,60	5 897,84 4 056,31

| LIVRÉ AVEC CLÉ DE SERRAGE LARDON ET BUTÉE LATÉRAL |

SETS TARAUDS MACHINE



SET DE TARAUD M4-M8

TYPE HRC60 C-HH-TC



Référence fournisseur	Qualité	Goujure	Type de trou	Revêtement	Entrée	Code	Prix € net HT
C9 135F01	CARBURE	DROITE		TiCN	D / 4 5P	045710	231,00

TARAUDS CARBURE

TARAUD FANAR CARBURE TiCN HRC60	Code	Prix tarif € HT
C9 135F01 0030 M3	045700	27,90
C9 135F01 0040 M4	045701	28,78
C9 135F01 0050 M5	045702	29,64
C9 135F01 0060 M6	045703	33,13
C9 135F01 0080 M8	045704	40,10

- HRC 60
- REVÊTEMENT : TiCN
- GOUJURE : DROITE

TARAUD VERGNANO CARBURE V MAXX H130	Code	Prix promo € HT
A000301309A1AV0 M3x0,5	042729	142,00
A000401309A1AV0 M4x0,7	042730	142,00
A000501309A1AV0 M5,08	042731	143,93
A000601309A1AV0 M6x1,00	042732	145,74
A000801309A1AV0 M8x1,25	042733	166,02
A001001309A1AV0 M10x1,5	042734	183,93
A001201309A1AV0 M12x1,75	042735	232,16

- H130
- REVÊTEMENT : V MAXX
- GOUJURE : DROITE

BRAS DE TARAUDAGE ET PERÇAGE ÉLECTRIQUE



MODÈLE	BTE 1000-10T	BTE 1000-12T	BTE 1000-16T	BTE 1000-10PT
CAP	M3 M10	M3 M12	M3 M16	M3 M10
VITESSE	1 000 T/MIN	600 T/MIN	312 T/MIN	1 000 T/MIN
RAYON	1 100 MM	1 100 MM	1 100 MM	1 100 MM
DOUILLE	D19	D19	D19	D19 + MANDRIN AUTO SERRANT
MANDRIN	GR1	GR1	GR1	GR1
TÊTE	MULTIDIRECTIONNELLE	MULTIDIRECTIONNELLE	MULTIDIRECTIONNELLE	FIXE
PUISSANCE	600W 220V	600W 220V	600W 220V	600W 220V
CODE	0450000	0450001	0450002	0450003
PRIX € NET HT	1 365,00	1 430,00	1 540,00	1 668,00

PRIX PROMOTIONNELS NET HT - OFFRE VALABLE DANS LA LIMITE DES STOCKS DISPONIBLES - 31-12-2022*

* TECHMO SATECH NE PEUT GARANTIR LES PRIX SUR L'ANNÉE 2022

Nous nous donnons la possibilité de modifier les prix promotionnels en fonction des éventuels changements de prix de nos partenaires.

TECHMO

30 rue de Montaran
45400 FLEURY LES AUBRAIS
commercial.techmo@techmo.fr
☎ 02 38 61 48 10
☎ 02 38 84 39 63

TECHMO TOULOUSE

18 chemin de la Violette
31240 L'UNION
magasin.toulouse@techmo.fr
☎ 05 61 61 34 35
☎ 05 61 61 34 44

TECHMO BORDEAUX

9 rue Laplace
33700 MERIGNAC
magasin.toulouse@techmo.fr
☎ 05 61 61 34 35
☎ 05 61 61 34 44

SATECH

28 rue Alain Gerbault
72100 LE MANS
magasin@satech.fr
☎ 02 43 40 05 05
☎ 02 43 40 00 99